

TICO TICO VEST

by Cecilia Lalanne
& Lucia Segovia



MANOS
DEL URUGUAY
— EST. 1968 —



Tico Tico Vest

by Cecilia Lalanne
& Lucia Segovia

Our *Alegria Grande* yarn looks spectacular in this new design: *Tico Tico Vest*. A piece that is knitted combining flat and circular knitting techniques, achieving a simple and delicate texture that perfectly mixes the variegated colors of one of our new shades from the Spring 2024 collection.

Finished Measurements

Sizes: 1, (2, 3, 4, 5, 6, 7, 8)

Bust circumference:

34 (37.5, 41, 45, 49, 52.5, 56, 60)" / 86 (95,

104, 114, 124, 134, 143, 152) cms

Shown in size 1 with zero ease.

Yarn

Alegria Grande by Manos del Uruguay, (75% superwash merino, 25% polyamide) approx.

197 yds / 180 mts per 100 g

Color A: 2 (3, 3, 4, 4, 5, 5, 6) skeins.

Color B: 1 (1, 2, 2, 2, 3, 3, 3) skeins.



Needles and Tools

- Circular needles 4,0 mm / #6 US
- One pair of straight needles in size 4,0 mm / #6 US. (Or size to obtain gauge)
- 1 tapestry needle.

Gauge

23 sts and 26 rows = 4" [10 cm] in pattern stitch, after blocking.

Abbreviations

CO- Cast on

BO- Bind off

K- Knit.

P- Purl.

RS- Right Side.

WS- Wrong Side.

Sts- Stitches.

BOR- Beg. of the round.

S11 k1 pssso- slip knit pass slipped stitch over

K2tog- knit two stitches together

RT- Right twist- Knit into the second stitch on the left needle, knit the first stitch and remove both stitches at once.

Video reference for RT:

<https://www.youtube.com/watch?v=frXEFXVs4qW>

Instructions

We will begin this pattern working in circular knitting until the shape of the armhole, from here we will begin to work the front and back separately. After having both pieces knitted we will join the shoulders, and make the elastics for the armholes and neck.

If you are knitting with a nuanced color, as in the sample, it is recommended to alternate the different skeins of the same color to avoid the pulling.

BODY - Front and Back

With 4.0 mm circular needles using color B, CO 213 (233, 257, 281, 305, 329, 353, 373) sts. Place one marker for BOR, knit 107 (117, 129, 141, 153, 165, 177, 187) sts, place a marker to differentiate the front from the back.

Work in k1, p1 rib until piece measures 2.0" / 5.5 cm from the cast on edge.

Change to color A and continue **working the pattern in the round** for 7 (7, 7, 8, 8, 8, 9, 9) " / 17 (17, 17, 20, 20, 20, 23, 23) cms, ending with a row 3.

Pattern in the round:

Round 1: (RT, k1) to last 2 sts, RT.

Round 2: Knit.

Round 3: K2, (RT, k1) to end.

Round 4: Knit.

From here front and back pieces are worked separately with straight knitting.

Next round: BO the first 6 (6, 8, 8, 10, 10, 12, 12) sts., knit to last 6 (6, 8, 8, 10, 10, 12, 12) sts. before marker, BO the next 12 (12, 16, 16, 20, 20, 24, 24) sts., knit to last 6 (6, 8, 8, 10, 10, 12, 12) sts., BO those last sts, cut yarn. - 189 (209, 225, 249, 365, 289, 305, 325) sts.

Keep on hold the remain 94 (104, 112, 124, 132, 144, 152, 162) sts from the back and continue working only on the 95 (105, 113, 125, 133, 145, 153, 163) sts from the front.

FRONT - Armhole Shape

Starting with the RS row facing you BO 3 (3, 5, 5, 7, 7, 9, 9) sts. at the beginning of the next 2 rows, then BO 2 (2, 4, 4, 6, 6, 8, 8) sts. at the beginning of the next 2 rows. - 85 (95, 95, 107, 107, 119, 119, 129) sts
(All this while I continue working with the Flat Pattern)

Flat Pattern:

Row 1: (RT, k1) to end.

Row 2: Purl.

Row 3: K2, (RT, k1)

Row 4: Purl.

Next row (RS) (decreasing): K2, sl1 k1 pssso, work **flat pattern** to last 4 sts, k2tog, k2.

Next row: Purl.

Work last 2 rows 6 (6, 6, 8, 8, 10, 10, 12) times in total - 73 (83, 83, 91, 91, 99, 99, 105) sts.

Continue working **flat pattern** until 5 (5.5, 6.5, 7, 7, 8, 9, 9.5)" / 13 (14.5, 16.5, 18.5, 18.5, 21, 22.5, 24.5) cms from the armhole shape beginning.

FRONT - Neck Shape

Work on **flat pattern** for the first 22 (26, 26, 29, 29, 31, 31, 33) sts., BO 29 (31, 31, 33, 33, 37, 37, 39) sts., work on **flat pattern** next 22 (26, 26, 29, 29, 31, 31, 33) sts.

From here you will work both shoulders, right and left, separately as follow:

All WS rows: Purl

BO 2 sts. on each side of the front neckline for the next 3 RS rows, then BO 1 sts. on each side of the front neckline for the next 3 RS rows. - 13 (17, 17, 20, 20, 22, 22, 24) sts. remain on each side.

Continue working on **flat pattern** each shoulder until measures 17 (17.3, 18, 20, 20, 21, 23, 23.5)" / 43 (44, 46, 51, 51, 54, 58, 60) cms from the cast on edge.



BACK - Armhole Shape

Place on the needle the back stitches that were on hold.

Starting with the RS row facing you BO 3 (3, 5, 5, 7, 7, 9, 9) sts. at the beginning of the next 2 rows, then BO 2 (2, 4, 4, 6, 6, 8, 8) sts. at the beginning of the next 2 rows. - 84 (94, 94, 106, 106, 118, 118, 128) sts

(All this while I continue working with the Flat Pattern)

Next row (RS) (decreasing): K2, sl1 k1 pssso, work **flat pattern** to last 4 sts, k2tog, k2.

Next row: Purl.

Knit the last 2 rows 6 (6, 6, 8, 8, 10, 10, 12) times in total - 72 (82, 82, 90, 90, 98, 98, 104) sts.

Continue working on **flat pattern** until 15 (16, 16.5, 18, 18, 19.5, 21, 22)" / 39 (40, 42, 47, 47, 50, 54, 56) cm from the cast on edge.

IMPORTANT: finish with a WS row.

Continue working on **flat pattern** for 13 (17, 17, 20, 20, 22, 22, 24) sts., BO. 46 (48, 48, 50, 50, 54, 54, 56) sts., continue working on **flat pattern** for 13 (17, 17, 20, 20, 22, 22, 24) sts.

From here you will work both shoulders, right and left, separately as follow:

Row 1 (RS): Work on flat pattern.

Row 2 (WS): Purl.

Repeat these 2 rows 3 more times or as many times as necessary to equate the length of the back with the front piece.

Join the shoulder of front and back using the 3-needle bind off method.

NECKLINE RIB

With color B, starting from the centre back of the neckline, pick up 2 sts. every 3 sts. around the entire contour of the neckline.

Join for working in the round and work in k1, p1 rib for 1.2" / 3.0 cms.

Bind off using tubular bind off method.

ARMHOLE RIB

Work the same way for both armholes.

With color B, starting from the middle of the armhole, pick up 2 sts. every 3 sts. around the entire contour of the armhole.

Join for working in the round and work in k1, p1 rib for 1.2" / 3.0 cms.

Bind off using tubular bind off method.

FINISHING:

Weave in ends. Steam- or wet-block piece to finished measurements.

MEASURES

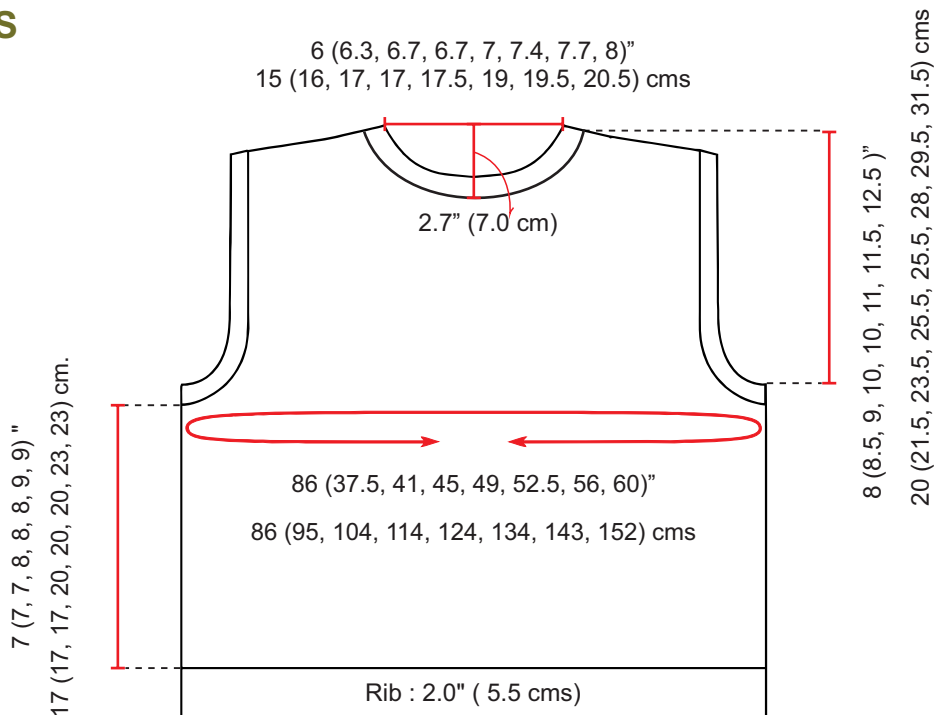



MANOS
DEL URUGUAY
— EST. 1968 —

